



THE WOOD
COMPACT



FINSA

solutions in wood



FINSA

solutions in wood

Photo: Actiu

COMPACMEL PLUS

THE WOOD COMPACT

CONTENTS

04 ENVIRONMENT AND SUSTAINABILITY

06 MAIN FEATURES AND APPLICATIONS

08 MAIN ADVANTAGES

10 ANTIBACTERIAL CERTIFICATION

12 TECHNICAL CERTIFICATIONS - AIDIMA

13 Assessment of the baseboard's
resistance

13 Assessment of the surface resistance

14 Technical tests

16 RANGE, QUALITIES AND FORMATS

17 DESIGNS

18 APPLICATIONS, PROJECTS AND IDEAS

Recommend by ...

Office facilities

Educational facilities

Washroom and Toilet cubicles, and

changing rooms

Sports facilities

Commercial and sports facilities

Hotel and hospitality equipment

Hospital equipment and facilities

Ephemeral art

36 TECHNICAL INFORMATION

Technical recommendations

Installation recommendations

Edge sealing recommendations

Hardware recommendations

Certifications

Technical data



LEED CREDITS: SUSTAINABLE CONSTRUCTION

Our products offer LEED credits in the following areas:

- Recycled content
- Regional materials
- Rapidly renewable materials
- Certified wood
- Low-emission materials

CERTIFICATIONS: WOOD FROM SUSTAINABLE FORESTS

The Chain of Custody certifies the route of the raw materials from the forest to the consumer / customer, including all stages of the process; i.e., it warrants that the products purchased are made with materials from sustainably managed forests.

This warranty through PEFC and FSC[®] certificates, includes the production and marketing of wood-based products.



The mark of
responsible forestry

ENVIRONMENT AND SUSTAINABILITY



TRANSPARENCY: ECOLOGICAL PRODUCT FOOTPRINT

In 2011, FINSA became the first technical wood manufacturer on the Iberian Peninsula providing the Environmental Product Declaration (EPD) for its products.

The EPD is a tool for conveying clear, transparent information on the impact of a given product upon the environment during every stage of its life cycle.

In the case of our products, it confirms that wood is a material that keeps capturing greenhouse gases throughout our entire production process.

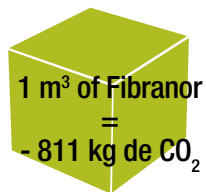
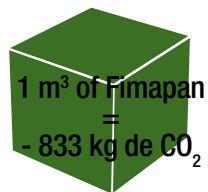

DID YOU KNOW...?

The production process of CompacMel Plus saves up to 80% of the emission of greenhouse gases compared to the traditional phenolic compact process.

FEATURES AND APPLICATIONS

A SOLUTION IN WOOD
SPECIALLY DESIGNED FOR USE
IN HIGHLY HUMID INDOOR
ENVIRONMENTS OR
APPLICATIONS REQUIRING
HIGH RESISTANCE.

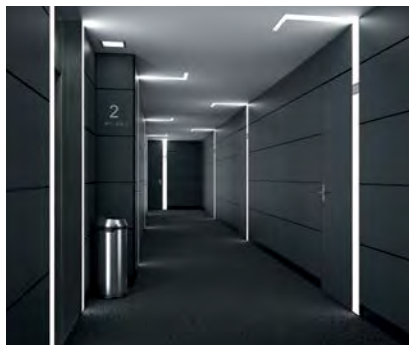
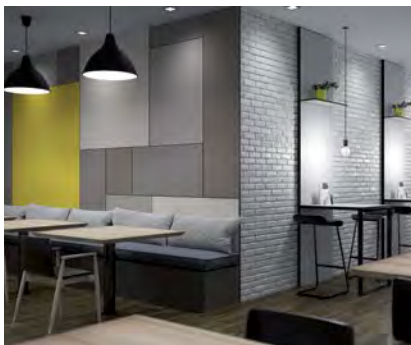

FEATURES

The COMPAC PLUS / COMPACMEL PLUS products come from our strong commitment to technological development and innovation, diversifying our range of products to provide solutions for the most demanding projects.

COMPAC PLUS is a high-density wood fibre board (>1000 kg/m³), with excellent physical and mechanical properties.

With a wide range of modern trendy designs, COMPACMEL PLUS also features a high-strength melamine coating.



APPLICATIONS

- Sports facilities: lockers, locker rooms and benches, shower screens * ...
- Commercial facilities: fitting rooms, store counters...
- Cultural center's facilities: wardrobe, luggage storage...
- Air and land transport facilities.
- School and office furniture: bookcases, tables and desks..
- Kitchen furniture: countertops*
- Hospital equipment: tables, beds, cabinet doors...
- Hotels and hospitality equipment...
- Facilities for common areas of buildings
- Storage: cupboards, shelves..
- Suspended dividers in public toilet facilities
- Panels
- Interior doors

* for this application it is recommended to seal the edges.

MAIN ADVANTAGES



ENVIRONMENTALLY FRIENDLY: SUSTAINABLE, 100% RECYCLABLE MATERIAL.

E1: LOW FORMALDEHYDE CONTENT



EXCELLENT MECHANICAL PROPERTIES (BENDING STRENGTH, INTERNAL BOND, RESISTANCE TO IMPACT,...) AND DIMENSIONAL STABILITY



HIGH RESISTANCE TO MOISTURE (EXCEEDS THE V313 AND V100 TEST REQUIREMENTS)



COMPETITIVE COST

LOW TOOL WEAR



WIDE RANGE OF DECORS

VERSATILE DESIGN



EASY MACHINE WORK (CUTTING AND DRILLING) AND INSTALLATION.

STANDARD TOOLS AND HARDWARE



CERTIFIED ANTIBACTERIAL SURFACE



FIRE-RETARDANT QUALITY AVAILABLE



ANTIBACTERIAL CERTIFICATION



CERTIFICATION

IMSL
INDUSTRIAL MICROBIOLOGICAL SERVICES LTD

The CompacMel Plus surface has been certified by an external laboratory, the IMSL (Industrial Microbiological Services) in the UK, following the procedures outlined by ISO 22196: 2011, which confirms that the performance of CompacMel Plus inhibits the growth and development of bacteria, without affecting its coating features.

Tested with the following bacteria:

- *S. aureus*, which can produce a large variety of diseases, ranging from skin and mucous infections, to life-threatening diseases such as meningitis, pneumonia, etc.
- *E. coli*, which can cause diarrhea and serious intestinal issues.

ANALYSIS CERTIFICATE

CERTIFICATE NO. 1023308.1E-1

IMSL
Industrial Microbiological Services (UK)
www.imsl-uk.com

Method: Calculation of antibacterial activity by using ISO 22196: 2011

RESULTS (AS CFU CM-2)

SAMPLE

		CONTACT	TIME	REDUCTION	LOG % DIFFERENCE
COMPACMEL PLUS	<i>E. Coli</i>	1.7E+04	≤ 1.0	≥ 4.2	> 99.99%
	<i>S. aureus</i>	2.0E+04	≤ 1.0	≥ 4.3	> 99.99%

The above data show the difference between the initial and final bacterial populations after contact with sample surfaces, referenced for 24 hours at 35 °C, at a relative humidity of 95%.

TECHNICAL CERTIFICATIONS:



CERTIFICATION

AIDIMA, the Technological Furniture, Wood, Packaging and Similar Products Institute, is a non-profit organization established in 1984, equipped with one of the best Technological Institutes in Europe. A complete characterization of CompacMel Plus has been conducted at their laboratories, assessing both the support as well as the coating properties.

"The tested product CompacMel Plus meets the requirements of the following standards, which apply to kitchen and bathroom furniture":

- UNE 56 842
- UNE 56 843
- UNE 56 867
- UNE 56 868
- ISO 19712-1



THERMAL CONDUCTIVITY

Thanks to the good thermal conductivity values achieved, CompacMel Plus is a perfect product for wall cladding, as it substantially improves thermal insulation, and thus reduces energy consumption.

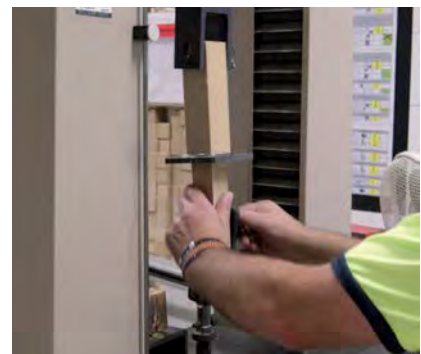

ASSESSMENT OF THE BASEBOARD'S RESISTANCE

FEATURE	STANDARD	UNIT	COMPACMEL PLUS
Density	EN 323	kg / m ³	1050-1100
Surface pull-off	EN 311	N / mm ²	> 3.5
Surface screw pull-off	EN 13446	N	> 1300
Impact resistance. Fall height	UNE 56754	mm	> 2000
Swelling in thickness after 24h immersion in water	EN 317	%	0.15
Thermal conductivity	EN 12667	W / m K	0.12

ASSESSMENT OF THE SURFACE RESISTANCE WHITE SR 209 REFERENCE

FEATURE	STANDARD		HPL STANDARD REQUIREMENT	COMPACMEL PLUS*
Appearance	UNE 56867	Assessment	Zero defects	Zero defects
Stain resistance	EN 438-4	Group 1 agents. Assessment	≥ 5	5
		Group 2 agents. Assessment	≥ 5	5
		Group 3 agents. Assessment	≥ 4	5
Stain resistance. Kitchen furniture. Working planes	UNE 56 842	Assessment	≤ 1	0
Stain resistance. Bathroom furniture. Toilet planes	UNE 56 867	Colour. Assessment	≥ 4	5
		Gloss. Assessment	≥ 3	5
Abrasion resistance	EN 438-4	Initial point IP (cycles)	≥ 150	900
		Resistance (cycles)	≥ 350	1150
Resistance to ball drop	EN 438-4	Fall height (mm)	≥ 1800	≥ 2000
Resistance to ball drop. Kitchen furniture	UNE 56 842	Assessment	No cracks	No cracks
Resistance to ball drop. Bathroom furniture	UNE 56 867	Assessment	≤ 1	0
Resistance to ball drop. Solid surfaces.	ISO 19712-1	Assessment	No cracks	No cracks
Colour fastness to light	EN 438-4	Grayscale. Assessment	≥ 4 - 5	5
Steam resistance. Colour / gloss assessment	UNE 56 867	Colour. Assessment	≥ 4	5
		Gloss. Assessment	≥ 4	5
Resistance to dry heat at 180 °C	UNE 56 867	Colour. Assessment	≥ 4	5
		Gloss. Assessment	≥ 4	5
Resistance to moist heat at 100 °C	EN 438-4	Other types of finishing. Assessment	≥ 4	5
Crack resistance	EN 438-4	Assessment	≥ 4	5
Cigarette burn resistance	EN 438-4	Assessment	≥ 3	5
Scratch resistance	EN 438-4	Smooth finishing	≥ 2	5
Thermal shock cycles	UNE 48025	Assessment	Zero defects	Zero defects
Resistance to attack by hydrochloric acid	Internal method	Assessment	---	5

TECHNICAL TESTS

FEATURED DATA

In tests conducted by AIDIMA, the product's resistance to changing temperature and humidity conditions was assessed.

The following tests were conducted, whose results are shown below:



	TEST RESULTS		TEMPERATURE
	TIME		SUBMERGED IN WATER
	RELATIVE HUMIDITY		

THERMAL STABILITY	
STANDARD EN 263	
LONGITUDINAL INCREASE	- 0,1 mm/m
THICKNESS INCREASE	- 0,80 %

DIMENSIONAL STABILITY AT HIGH TEMPERATURE	
STANDARD EN 438	
LONGITUDINAL INCREASE	0,37%
TRANSVERSAL INCREASE	0,38%

RESISTANCE TO HOT WATER	
STANDARD EN 263	
100 CYCLES	
LONGITUDINAL INCREASE	0,27 %
THICKNESS INCREASE	6,3 %

THERMAL SHOCK CYCLES	
STANDARD UNE 48025	
40 CYCLES	
ZERO DEFECTS	

DIMENSIONAL STABILITY TO HUMIDITY CHANGES	
STANDARD EN 318	
	I. 30%→65%→85%
	II. 85%→65%→30%
LONGITUDINAL INCREASE	0,22%
TRANSVERSAL INCREASE	0,33%

RANGE QUALITIES, FORMAT AND DESIGNS

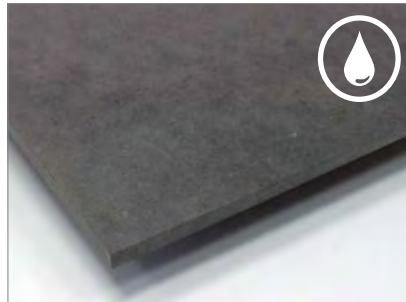

COMPAC PLUS

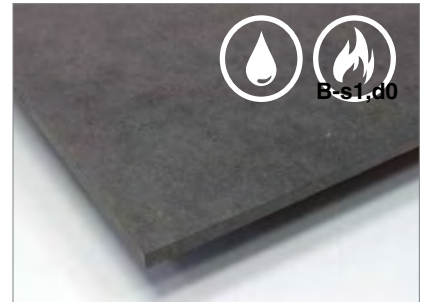

**COMPAC PLUS
FIRE-RETARDANT**

Size (mm)	2850 x 2100			
Thickness (mm)	8	10	12	13
Units / pack	36	28	24	22

Minimum: 1 pack
Production possibilities:
thickness 8-13 mm

Size (mm)	2850 x 2100
Thickness (mm)	8
Units / pack	36

Minimum: 1 pack
Production possibilities:
thickness 8-13 mm

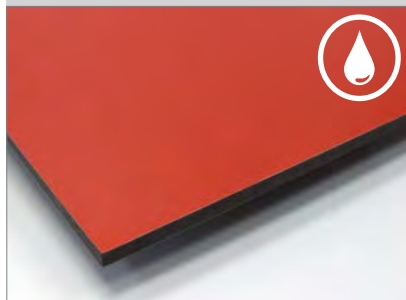

COMPACMEL PLUS

Melamine faced



**COMPACMEL PLUS
FIRE-RETARDANT**

Melamine faced

STANDARD RANGE

Size (mm)	2850 x 2100
Thickness (mm)	13

Minimum: 1 board
Designs:
CompacMel Plus Range (Soft III Texture)

FLEXIBLE RANGE

Format (mm)	2850 x 2100			
Thickness (mm)	8	10	12	13
Units / pack	36	28	24	22

Min.: 1 pack CompacMel Plus range (soft III)
2 packs Gama Duo and
Blanco Super (soft III)*

STANDARD RANGE

Size (mm)	2850 x 2100
Thickness (mm)	8

Minimum: 10 boards
Designs:
CompacMel Plus Range (Soft III Texture)

FLEXIBLE RANGE

Format (mm)	2850 x 2100			
Thickness (mm)	8			
Units / pack	36			

Min.: 1 pack CompacMel Plus range (soft III)
2 packs Gama Duo and
Blanco Super (soft III)*

Veneer supply option:
COMPAC PLUS NATUR

Consult our sales network.

* Available with a minimum order quantity of 1 pack in any Gama Duo décor. Please ask your Finsa sales representative.

COMPACMEL PLUS RANGE

TEXTURE: SOFT III

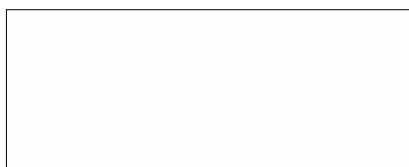

78E_WHITE SR209

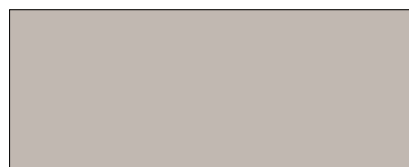

15R_GRIS COCO

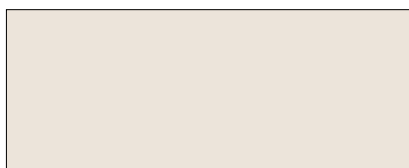

183_CREMA 005

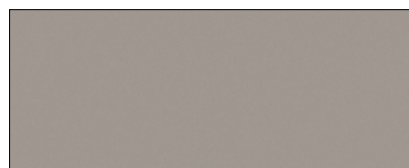

11R_VISON CHIC



01Q_GRIS TORTORA

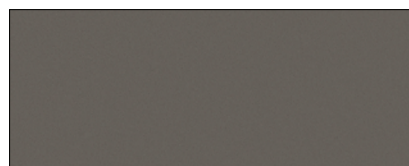

53S_MOKA CHIC



U12_NATURAL GREY

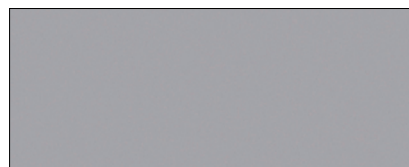

72E_ALUMINIO AROSA

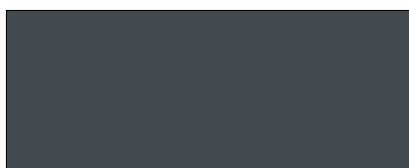

71A_GRIS GU



231_NEGRO



172_ROJO



139_AZUL EO



22G_AMARILLO SOL



54C_VERDE NATURAL

APPLICATIONS PROJECTS AND IDEAS

 estudi**bonjoch** s.l.
bonavista 6, int. pral. 4a 08012 Barcelona



DISSENY HUB BARCELONA BUILDING. PHOTOGRAPHY LOURDES JANSANA

RECOMMEND BY...

IGNASI BONJOCH
INTERIOR DESIGNER

WWW.BONJOCH.COM

Ignasi Bonjoch began his professional career in 1990 by founding the Bonjoch Studio. Throughout these 25 years, he has faced numerous projects in the field of interior design and ephemeral space, from the earliest stages of strategy and positioning, to final resolution.

Wood and its qualities have always had a prominent role in his portfolio, and that is why Finsa's decorative solutions have been integrated into several of his studio's flagship projects.

DISSENY MUSEUM
BARCELONA

Ignasi Bonjoch designs and plans the 2nd floor of the Disseny Hub Barcelona: the Design Museum that brings together the Design Museums in Catalonia:

"In the Museum we find many large, really heavy historical pieces, which we have arranged upon CompacMel Plus as an exhibition platform. This choice allowed us to move and place these pieces without fear of scratches, thanks to the highly resistant surface. The perfect edge cutting also allowed us to leave it visible, thus saving time and processes, without sacrificing quality and design."

DOWNLOAD THE VIDEO
FINSA / THE EXPERT'S OPINION
WITH IGNASI BONJOCH



OFFICE FACILITIES

COMPANY OFFICES AUTOMOTIVE SECTOR
VALENCIA (SPAIN)

DESIGNER: AC ARQUITECTURE
INSTALLER: ARMARIOS LEVANTE, S.L.
APPLICATION: BACKLIT PANEL







EDUCATIONAL FACILITIES

CHILDREN EDUCATION CENTRE
CALLOSA, ALICANTE (SPAIN)

DESIGNER: DESIGNER: ROCAMORA ARCHITECTURE AND ALEXANDRE
MARCOS

PHOTOGRAPHY: DAVID FRUTOS
APPLICATION: FURNITURE





BILBAO ARENA SPORTS PALACE
BILBAO (SPAIN)

DESIGNER: BILBAO EKINTZA, E.P.E.L.
APPLICATION: SANITARY CABINS

**WASHROOM AND TOILET
CUBICLES / CHANGING ROOMS**



**BAI GYM FITNESS CENTRE
BILBAO (SPAIN)**

**DESIGNER: MIABSA ARQUITECTURA INTERIOR, WWW.MIABSA.COM
APPLICATIONS: LOCKERS**

**FINSA 21 SPACE
MADRID (SPAIN)**

**DESIGNER: LILIAN FLORES
APPLICATION: TOILET**

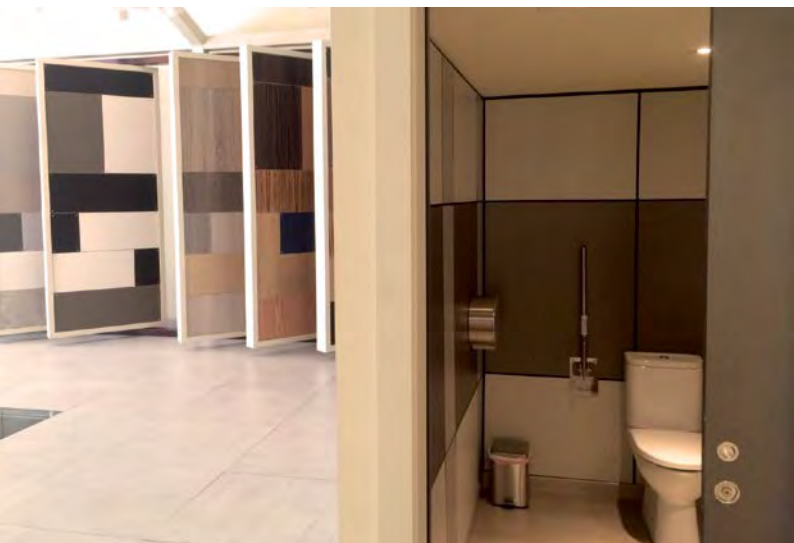

SPORTS FACILITIES

REAL AERoclub OF SANTIAGO
AMES (SPAIN)

DESIGNER: CARBAJO Y BARRIOS ARQUITECTOS / JUAN PINTO
APPLICATIONS: LOCKERS / INSTALLATIONS
PRODUCT: COMPAC PLUS NATUR

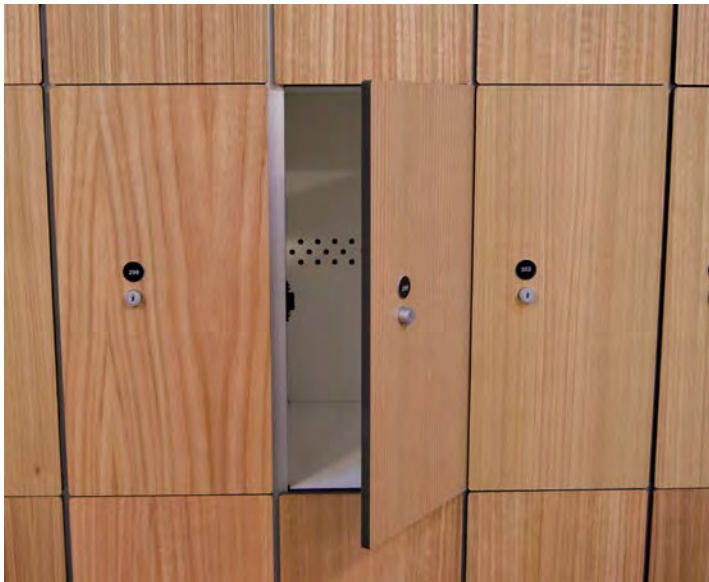
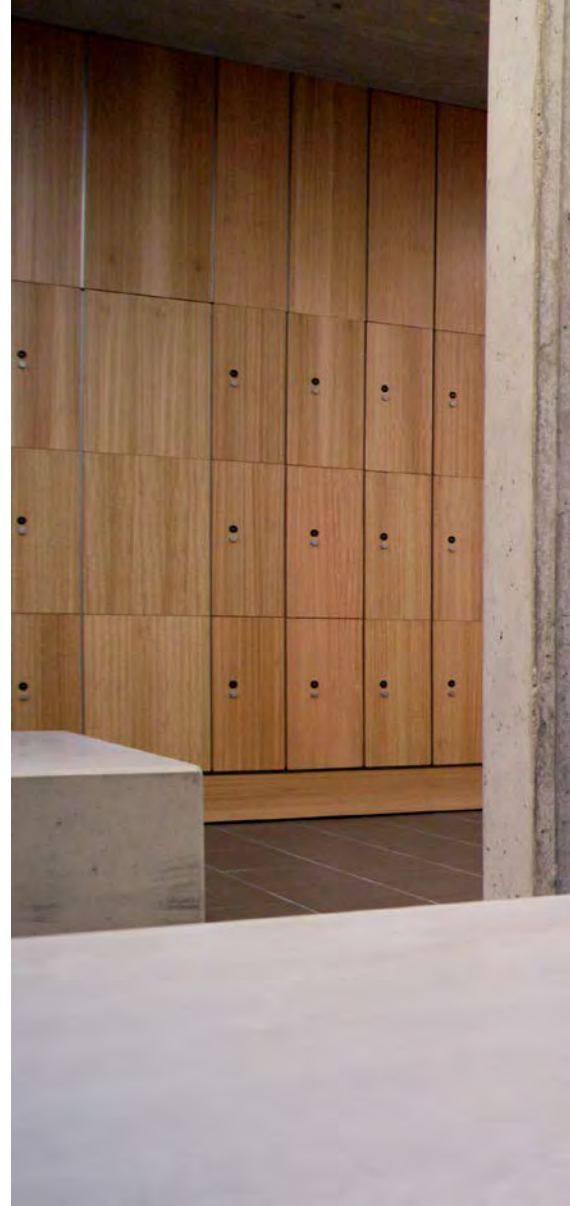



COMMERCIAL AND SPORTS FACILITIES



IMD ERMUA
GUIPUZCOA (SPAIN)

DESIGNER: EBANISTERÍA LANDA, S.L. AND COMERCIAL
VILARRASA
APPLICATION: COUNTER

RESTAURANT
MADRID (SPAIN)

DESIGNER: ANTONIO VELA COSSIO
APPLICATION: FURNITURE



**HOTEL AND HOSPITALITY
EQUIPMENT**



HOSPITAL EQUIPMENT AND FACILITIES

HOSPITAL DE VALDECILLA
SANTANDER (SPAIN)

DEVELOPER: UTE VALDECILLA (FERROVIAL AGROMAN, S.A., AND SIECSA CONSTRUCCIÓN Y SERVICIOS)
WWW.FERROVIAL.COM AND WWW.SIECSA.COM

INSTALLER: JAVAL, S.L.

APPLICATIONS: CUPBOARDS, WINDOW FRAMES, COUNTERTOPS, AND PEDIATRICS BABY CHANGING FACILITIES



COMPACMEL PLUS DATA SHEETS

38 TECHNICAL RECOMMENDATIONS

Storage and acclimatization recommendations

Handling and machine work recommendations

40 INSTALLATION RECOMMENDATIONS

General information

Specific recommendations

Wall cladding

Sanitary cabins

43 EDGE SEALING RECOMMENDATIONS

44 HARDWARE RECOMMENDATIONS

47 CERTIFICATIONS

48 TECHNICAL INFORMATION SHEETS

Compac plus

Compacmel plus

Fire-retardant Compac Plus

Fire-retardant Compacmel Plus

These are just indicative technical data. Due to continuous product development, as well as that of the standards by which products are governed, some parameters may change.

For more information please visit the website: www.finsa.com



TECHNICAL RECOMMENDATIONS

COMPACMEL PLUS

Proper board storage and packaging prevents undesirable deformations, and helps preserve flatness.

STORAGE AND ACCLIMATIZATION RECOMMENDATIONS

STORAGE.

It should be stored in closed, ventilated, dry storage rooms, protected from sun, rain, frost and chemical splashes, in compact stacks.

Pallets shall be placed upon flat, levelled surfaces, and the boards shall remain packaged in similar conditions to those of the original packaging, in order to properly retain

their properties. When packages are stacked, it is recommended that the runners be aligned vertically to prevent warping.

Prevent boards from being subject to different humidity and temperature conditions on each of their sides.

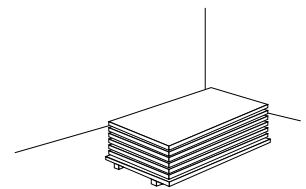

ACCLIMATIZATION.

Wood and all wooden boards, given their hygroscopic properties, capture and release moisture to surrounding environment, depending on the temperature and humidity of such environment, causing dimensional variations.

Preconditioning of boards is recommended. Before processing, it is recommended to let them get adapted to the environment for at

least 48 hours before use.

In case of on-site use (coating, room dividers, etc.), the boards must be stabilized at the installation site in order to achieve balance and minimize dimensional variations once installed.

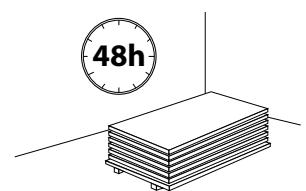

HANDLING AND MACHINE WORK RECOMMENDATIONS

HANDLING.

The product must be handled with appropriate care, like with any other melamine-coated board, avoiding intense friction between surfaces that may damage the decorative side.

CLEANING.

The product can be cleaned with a damp cloth, and a mild cleaning agent in small doses. Abrasive elements and excessively acidic or alkaline solutions should be avoided. Prolonged exposure to wet surfaces and / or direct contact with water should be avoided.

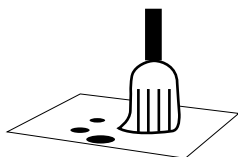

CUTTING AND MACHINING.

Common tools can be used for cutting and machine working the wooden boards, just as for any other wood-based panels, although specific parameter settings may be required (cutting speed, feed rate), for a good finishing. To increase tools service life, the use of diamond cutting tools is recommended.

Product features allow it to be machine worked, and to use visible edges.

It is recommended to consult your usual tools provider for further information and advice.

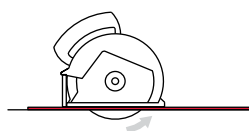

INSTALLATION RECOMMENDATIONS 1/2

GENERAL INFORMATION

Proper board storage and packaging prevents undesirable deformations, and helps preserve flatness.

The material should be dry, and NEVER exposed to or in contact with stagnant water, not even during the assembly process.

- Follow all technical specifications regarding dimensional changes when designing the facility, considering expansion joints in the case of coatings, or suitable clearance in the case of rebates. Likewise, when fasteners are used, which should allow adequate dimensional variations during the facility's service life,

- To ensure appropriate expansion, there should be at least one joint between panels for 2 mm / m linear board.
- There should be no more than a single fixed point in the entire assembly unit, the remaining fastening points should enable movement.

- In the event of contact with liquid water (not stagnant), edges must be SEALED.

- When using adhesives, they must be flexible to enable panel movement.

- In the case of using countersunk screws, they should be placed with support rosettes. If it is a ball screw, it will cover the sliding hole.

- For decorative purposes, wax, oil or vaseline can be applied to the visible edge to enhance its colour.

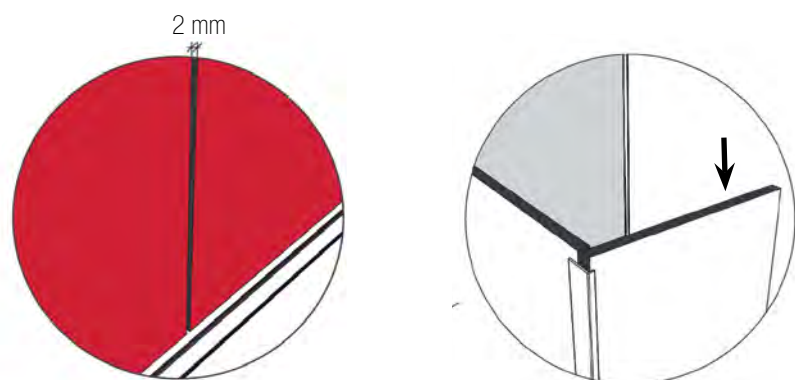

SPECIFIC RECOMMENDATIONS

Compacmel Plus boards are suitable for installation as paneling in areas requiring intensive cleaning, for their mechanical and surface properties; and are suitable for the manufacture of sanitary cabins and bathrooms dividers, thanks to their moisture resistance and easy-to-clean surfaces.

WALL CLADDING

Compacmel Plus is suitable for panel coating ventilated walls, in which the board is attached to a substructure, which, in turn, is attached to the brick, concrete or wooden wall, ensuring appropriate ventilation and air circulation.

it should always be mounted on a substructure, never directly onto the wall, even if it is completely flat, and the wall should be checked to confirm that it is completely dry before panel installation.

Ventilation of the rear chamber between the board and the wall ensures the appropriate temperature and humidity balance on both sides of the board, preventing deformation by

differential variations. It is advisable to ensure that the air circulation gap is at least 20 mm thick, and that ventilation is provided from the bottom to the top.

The substructure can be built with board strips, wood, steel or aluminum, and can be made with horizontal and / or vertical profiles (battens).

Compacmel Plus can be attached to the substructure by:

- visible fasteners, with screws or rivets from the visible side to the substructure,



- concealed fastening, with hanging aluminum clamps or adhesive ribbons on the back side of the board to be fastened or attached to the substructure, following the above stated recommendations (general notes).

In case of hanging horizontal mounting rails, it should be done in such a way that it ensures vertical ventilation.

FOR COATINGS WITH VISIBLE MECHANICAL FASTENING

When using screws or rivets as fasteners, the following is required:

- Arrange the fasteners starting from the center of the board.

- Only one fixed point per assembly unit, all others must be sliding points.

Fixed point means that in which the diameter of the bore matches the diameter of the fastening element, and will be located as near as possible to the center of the board.

A sliding point is one whose hole is larger than the fastener, at least 2 mm more per meter of board, taken from the fixed point. The diameter of the fastener will be large enough to cover the hole, and will be attached in such a way as to allow the movement of the board, without tightening the screw too much.

Maximum fastener distances

Maximum distance to the board edge - 10 mm.

Maximum distance between fasteners:

600 mm for 8 mm board thickness, and 800 mm for 13 mm board thickness.

INSTALLATION RECOMMENDATIONS 2/2

SPECIFIC RECOMMENDATIONS

Compacmel Plus boards are suitable for installation as paneling in areas requiring intensive cleaning, for their mechanical and surface properties; and are suitable for the manufacture of sanitary cabins and bathrooms dividers, thanks to their moisture resistance and easy-to-clean surfaces.

SANITARY CABINS

In general, the board should not be permanently exposed to standing water, either during use or during construction and assembly. To prevent this from happening, it should have support legs to prevent direct contact with the ground, and with height adjustment to compensate for floor surface unevenness.

It should facilitate unhindered air circulation

around the panels to ensure good performance.

Edges and all exposed areas should be sealed.

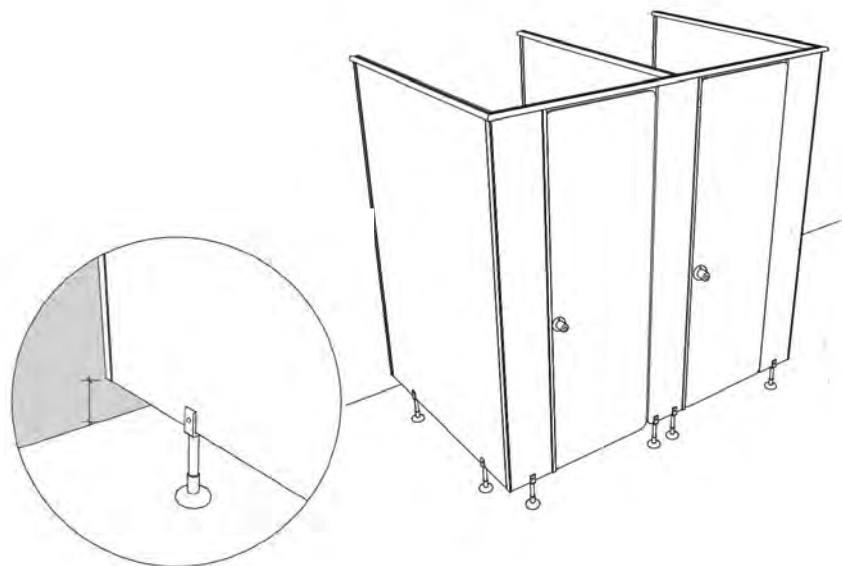

"The recommendations contained herein are only for general information purposes. It is recommended to always turn to professional experienced installers that know the design and regulatory requirements applicable in each case, for the correct installation of Compacmel Plus."

EDGE SEALING RECOMMENDATIONS



EDGE SEALING RECOMMENDATIONS FOR COMPACMEL PLUS WITH RENNER SEALANT FI---M192

DESCRIPTION

Sealant FI---M192----- is a two-component transparent sealer formulated with polymers endowed with highly insulating, moisture-resistant, climate change properties. This polyurethane sealant creates a protective high-strength film, with strong adhesion to the substrate, and high physical and chemical resistance.

MAINTENANCE

For maintenance and depending on the type of exposure the board shall be subject to, it is recommended that a new coat of FI--- M192 be applied annually from the 2nd year, while sanding the old paint film beforehand using 220 -240 grit sanding, in order to ensure that the properties remain unchanged throughout the board's service life.

APPLICATIONS

1. Beforehand, prepare the substrate with 180 grit sanding, then clean all the sanding residues. Before applying the product, the surface must be free from dust or grease.

2. Preparation of the mixture depends on the application method:

<u>APPLICATION METHOD</u>	<u>MIXING RATIO</u>
GUN / ROLLER	FI--- M192/----- (sealant) 1 part FC---M192/----- (catalyst) 5 parts

3. Once the mixture is ready for application, the following recommendations shall be taken into account:

No. of coatings	Max. 3
Recommended amount per coating	Max.: 50g/m ²
Interval between coatings	Max.: 1 hour
Lifetime of the mixture	4 hours

For more information: www.renneritalia.com

TECHNICAL TESTS

Tests performed by AIDIMA mentioned in Standard UNE EN 263:2002 have enabled a better assessment of board edge behaviour to changing temperature and humidity conditions, resulting from the application of edge sealant. FINSAs recommends the use of edge sealants in humid environments (e.g. sanitary cabins).

The information in this section is for general recommendations based on experiments. It is up to the end users to verify if this product suits their needs, regarding the type of instruments to be used, and the environmental application conditions.

HARDWARE RECOMMENDATIONS 1/2

HARDWARE

There is a wide range of hardware available in the market. Compacmel Plus is generally compatible with standard fittings available for wood panels or phenolic compact.

Following are some recommendations on hardware, fittings, and other complementary items, sold by some of the reference multinational companies in the sector,

structured by type of application.

It is recommended to follow the instructions and advice set forth by hardware manufacturers, and to consult them for further information and advice.

For more information, please visit the following reference websites:

Grass: www.grass.eu

Häfele: www.hafele.de

Hettich: www.hettich.com

HINGES



TIOMOS M9

Manufacturer: GRASS
Door thickness from 12 mm
Opening angle 110°



TIOMOS M0

Manufacturer: GRASS
Door thickness from 6 to 10 mm.
Opening angle 125°.



SPECIAL STAINLESS STEEL HINGES

Manufacturer: HÄFELE.
For 13mm body thickness, and thin doors 10-13mm thick.
Opening angle 240°.



PIANO STAINLESS STEEL HINGES

Manufacturer: HÄFELE.



SENSYS

Manufacturer: HETTICH
Hinge with 8mm cup. With brake.



PANELS



KEKU UNION HARDWARE SYSTEM

Manufacturer: HÄFELE.
Suspended mounting hardware.

PANEL MOUNTING SYSTEM

Manufacturer: HÄFELE.
The panel mounting system is used for wall coating. The basic structure is built with suspension profiles.



HORIZONTAL AND VERTICAL SUSPENSION PROFILES

Manufacturer: HÄFELE.



EILOX SUSPENSION PROFILES

Manufacturer: HÄFELE.
Same profile for wall and construction piece.

FURNITURE LOCKING SYSTEMS



DIALOCK

Manufacturer: HÄFELE.
Door thickness from 13 to 19 mm.
Electronic locking system (access control).



SYMO

Manufacturer: HÄFELE.
Closing system with interchangeable core cylinder.

SANITARY CABINS

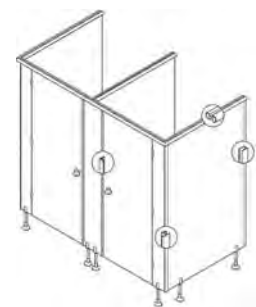

SYSTEM

Manufacturer: HÄFELE.
- Top profile
- Wall terminating profile
- Edge terminating profile
- Doorstop profile
- Forked leg
- Rotating knob with latch
- Aluminum screwing hinge
Only applicable to 13mm board thickness.

HARDWARE RECOMMENDATIONS 2/2

DRAWER SLIDES



TABLE V6

Manufacturer: HETTICH
Total extraction sliding and concealed under the drawer bottom. Mounting by sliding.

DOUBLE-WALL DRAWERS



INNOTECH / INNOTECH ATIRA

Manufacturer: HETTICH
Double-wall drawers.
Program based on platform concept.



ARCITECH

Manufacturer: HETTICH
Double-wall drawers for heavy fronts. Program based on platform concept. Full-extension slides.

SLIDING DOOR SYSTEMS



TOPLINE M

Manufacturer: HETTICH
For top-hung sliding door. Position of overlapping door. Max. weight: 35kg.



TOPLINE L

Manufacturer: HETTICH
For top-hung sliding door. Position of overlapping door. Max. weight: 50kg.



TOPLINE XL

Manufacturer: HETTICH
For top-hung sliding door. Position of overlapping door. Max. weight: 80kg.

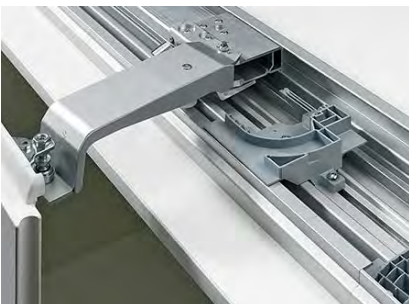

INLINE XL

Manufacturer: HETTICH
For top-hung sliding door. Position of flush-mounted door. Max. weight: 60kg.



SLIDELINE M

Manufacturer: HETTICH
For bottom-rolling sliding door. Position of overlapping door. Max. weight: 30kg.

CERTIFICATIONS

STANDARDS AND CERTIFICATIONS



ANTIBACTERIAL MARKING

Antibacterial surface according to ISO Standard 22196: 2011 certifying that the product offers benefits that inhibit the growth and development of bacteria.



FIRE-RETARDANT BOARD

European Standard EN 13501-1
"Classification based on fire performance of construction products and building elements."



MOISTURE RESISTANT BOARD

European Standard EN 622-5.
Requirements for general-purpose boards in humid environments.

CE



CE Mark in accordance with European Standard EN 13986 certified by AENOR.

ENVIRONMENTAL CERTIFICATIONS



FSC[®] certification guarantees the consumer that forest products come from rationally-managed forests, according to the Principles and Criteria of the Forest Stewardship Council.

For more info: www.fsc-spain.org



Forest Management Certificate PEFC/1435-00006. PEFC is an independent, non-governmental and non-profit entity whose aim is to promote sustainable forest management worldwide.

For more info: www.pefc.org

TECHNICAL DATA SHEETS

COMPAC PLUS

DOWNLOAD
THE COMPLETE
TECHNICAL DATA SHEET



TEST	PROPERTY	THICKNESS (mm)	UNITS
		8 -13	
EN 323	Density <small>(indicative information)</small>	>1000	kg/m ³
EN 319	Internal bond	1.8	N/mm ²
EN 310	Bending strength	50	N/mm ²
EN 310	Modulus of elasticity	5000	N/mm ²
EN 317	Thickness swelling in 24h	7	%
EN 318	Dimensional stability. Length / Width	0.4	%
EN 318	Dimensional stability. Thickness	6	%
EN 311	Surface soudness	1.7	N/mm ²
EN 382-1	Surface absorption (both sides)	>150	mm
EN 322	Moisture content	7±3	%
ISO 3340	Silica content	<0.05	% by weight
EN 120	Formaldehyde content	≤8 (E1 Class)	mg/100 g
EN 13329	Edge swelling	15	%
EN 13986:2004	Reaction to fire (*)	D-s2, d2 (*)	Euroclass
EN 321/ EN 317	Accelerated aging test (opt. 1) Swelling after cyclic test (V313)	12	%
EN 321 / EN 319	Accelerated aging test (opt.1) Internal bond after cyclic test (V313)	0.40	N/mm ²
EN 1087-1 EN 319	Accelerated aging test (opt.2) Internal traction after cooking test (V100)	0.20	N/mm ²
TOLERANCE IN NOMINAL DIMENSIONS			
EN 324-1	Thickness	± 0.20	mm
EN 324-1	Length and width	+/- 2 mm/m max 5 mm	mm
EN 324-2	Squareness	± 2	mm/m
EN 324-2	Edge straightness	± 1.5	mm/m

(*) For confined air gap or outdoor air gap below or equal to 22mm behind the COMPAC PLUS ≥9 mm. E classification for any other use / thickness condition. According to decision 2007/348/EC.

These physical and mechanical values meet/improve the values set forth under European Standard EN 622-5:2009, Table 4. Requirements for general-purpose boards in humid environments (Type MDF.H). COMPAC PLUS meets the Class E1 requirements (analyzed according to Standard EN 120) set forth under European Standard EN 622-1:2003.

COMPACMEL PLUS

DOWNLOAD
THE COMPLETE
TECHNICAL DATA SHEET



TEST	PROPERTY	THICKNESS (mm)		UNITS
		8	13	
EN 323	Density <small>(indicative information)</small>	>1000		kg/m ³
EN 319	Internal bond	1.8		N/mm ²
EN 310	Bending strength	50		N/mm ²
EN 310	Modulus of elasticity	5000		N/mm ²
EN 317	Thickness swelling in 24h	7		%
EN 318	Dimensional stability. Length / Width	0.4		%
EN 318	Dimensional stability. Thickness	6		%
EN 311	Surface soudness	1.7		N/mm ²
EN 322	Moisture content	7±3		%
ISO 3340	Silica content	<0.05		% by weight
EN 717-2	Formaldehyde emission	≤ 3,5 (E1 Class)		mg/m ² h
EN 13329	Edge swelling	10		%
EN 13986:2004	Reaction to fire (*)	D-s2, d2 (*)		Euroclass
EN 321/ EN 317	Accelerated aging test (opt. 1) Swelling after cyclic test (V313)	2		%
EN 321 / EN 319	Accelerated aging test (opt.1) Internal bond after cyclic test (V313)	0.60		N/mm ²
EN 1087-1 EN 319	Accelerated aging test (opt.2) Internal traction after cooking test (V100)	0.20		N/mm ²
TOLERANCE IN NOMINAL DIMENSIONS				
EN 324-1	Thickness	± 0.30		mm
EN 324-1	Length and width	+/- 2 mm/m max 5 mm		mm
EN 324-2	Squareness	± 2		mm/m
EN 324-2	Edge straightness	± 1.5		mm/m
COATING				
UNE-EN 14323	Resistance to scratching	≥2		n
UNE-EN 14323	Resistance to cracking	4		degree
UNE-EN 14323	Resistance to staining (group 3)	4		degree
UNE-EN 14323	Resistance to dry heat	4		degree
UNE-EN 14323	Resistance to impact	1500		mm
VISUAL DEFECTS				
UNE-EN 14323	Edge damage	≤10 (**), ≤3(***)		mm/m
UNE-EN 14323	Visual defects. Points	≤2		mm ² /m ²
UNE-EN 14323	Visual defects. Scratches	≤20		mm/m ²
	Abrasion resistance	Class	IP number of turns	WR number of turns
UNE-EN 14323	Abrasion resistance. Designs (inc. metallic)	1	<50	<150
UNE-EN 14323	Abrasion resistance. Solid colours	3A	>150	>350

(*) For confined air gap or outdoor air gap below or equal to 22mm behind the COMPACMEL PLUS ≥9 mm. E classification for any other use / thickness condition. According to decision 2007/348/EC.

(**) Commercial dimensions. (***) Boards cut to size.

These physical and mechanical values meet/improve the values set forth under European Standard EN 622-5:2009, Table 4. Requirements for general-purpose boards in humid environments (Type MDF.H). COMPACMEL PLUS meets the Class E1 requirements (analyzed according to Standard EN 120) set forth under European Standard EN 622-1:2003.

TECHNICAL DATA SHEETS

COMPAC PLUS FIRE-RETARDANT

DOWNLOAD
THE COMPLETE
TECHNICAL DATA SHEET



TEST	PROPERTY	THICKNESS (mm)	UNITS
		8 -13	
EN 323	Density <small>(indicative information)</small>	1050	kg/m ³
EN 319	Internal bond	1.8	N/mm ²
EN 310	Bending strength	45	N/mm ²
EN 310	Modulus of elasticity	4000	N/mm ²
EN 317	Thickness swelling in 24h	8	%
EN 318	Dimensional stability. Length / Width	0.4	%
EN 318	Dimensional stability. Thickness	6	%
EN 311	Surface soundness	1.7	N/mm ²
EN 382-1	Surface absorption (both sides)	>150	mm
EN 322	Moisture content	7±3	%
ISO 3340	Silica content	<0.05	% by weight
EN 120	Formaldehyde content	≤8 (E1 Class)	mg/100 g
EN 13329	Edge swelling	15	%
EN 13501-1	Reaction to fire	B-s1,d0	Euroclass
EN 1087-1 EN 319	Accelerated aging test (opt.2) Internal bond after cooking test (V100)	0.20	N/mm ²
TOLERANCE IN NOMINAL DIMENSIONS			
EN 324-1	Thickness	± 0.20	mm
EN 324-1	Length and width	+/- 2 mm/m max 5 mm	mm
EN 324-2	Squareness	± 2	mm/m
EN 324-2	Edge straightness	± 1.5	mm/m

These physical and mechanical values meet/improve the values set forth under European Standard EN 622-5:2009, Table 6, - Requirements for general-purpose structural boards in humid environments (Type MDF.HLS). FIRE-RESISTANT COMPAC PLUS meets the Class E1 requirements (analyzed according to Standard EN 120) set forth under European Standard EN 622-1:2003, and has EC certification issued by AENOR.

COMPACMEL PLUS FIRE-RETARDANT

DOWNLOAD
THE COMPLETE
TECHNICAL DATA SHEET



TEST	PROPERTY	THICKNESS	UNITS
		(mm)	
EN 323	Density (indicative information)	8 -13	
EN 319	Internal bond	>1050	kg/m ³
EN 310	Bending strength	1.8	N/mm ²
EN 310	Modulus of elasticity	45	N/mm ²
EN 310	Modulus of elasticity	4000	N/mm ²
EN 317	Thickness swelling in 24h	2	%
EN 318	Dimensional stability. Length / Width	0.4	%
EN 318	Dimensional stability. Thickness	6	%
EN 311	Surface soundness	1.7	N/mm ²
EN 322	Moisture content	7±3	%
ISO 3340	Silica content	<0.05	% by weight
EN 717-2	Formaldehyde emission	≤ 3,5 (E1 Class)	mg/m ² h
EN 13329	Edge swelling	10	%
EN 13501-1	Reaction to fire	B-s1,d0	Euroclass
EN 1087-1 EN 319	Accelerated aging test (opt.2) Internal traction after cooking test (V100)	0.20	N/mm ²
TOLERANCE IN NOMINAL DIMENSIONS			
EN 324-1	Thickness	+ 0.30	mm
EN 324-1	Length and width	+/- 2 mm/m max 5 mm	mm
EN 324-2	Squareness	± 2	mm/m
EN 324-2	Edge straightness	± 1.5	mm/m
COATING			
UNE-EN 14323	Resistance to scratching	≥2	n
UNE-EN 14323	Resistance to cracking	4	degree
UNE-EN 14323	Resistance to staining (group 3)	4	degree
UNE-EN 14323	Resistance to dry heat	4	degree
UNE-EN 14323	Resistance to impact	1500	mm
VISUAL DEFECTS			
UNE-EN 14323	Edge damage	≤10 (*) ≤3(**)	mm/m
UNE-EN 14323	Visual defects. Points	≤2	mm ² /m ²
UNE-EN 14323	Visual defects. Scratches	≤20	mm/m ²
	Abrasion resistance	Class	IP number of turns
UNE-EN 14323	Abrasion resistance. Designs (inc. metallic)	1	<50
UNE-EN 14323	Abrasion resistance. Solid colours	3A	>150
			WR number of turns
UNE-EN 14323	Abrasion resistance. Designs (inc. metallic)		<150
UNE-EN 14323	Abrasion resistance. Solid colours		>350

(*) Commercial dimensions. (**) Boards cut to size.

These physical and mechanical values meet/improve the values set forth under European Standard EN 622-5:2009, Table 6. - Requirements for general-purpose structural boards in humid environments (TYPE MDF.HLS). FIRE-RESISTANT COMPACMEL PLUS meets the Class E1 requirements (analyzed according to Standard EN 120) set forth under European Standard EN 622-1:2003, and has EC certification issued by AENOR.



THE WOOD COMPACT

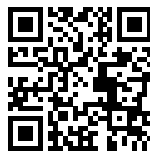

FINSA

solutions in wood